

AIR PLANT Operating and Maintenance Manual



www.precisionuk.co.uk



Company Registered Office: Crown House, Stockport, Cheshire, SK1 3RB
Registered in England and Wales No. 05058855
VAT No. 850 0700 67

*CPX Technology Building, Hazel Grove,
Stockport, Cheshire, SK7 5BW*

Tel: +44 (0) 161 487 2822

Fax: +44 (0) 161 487 2816

Email: info@precisionuk.co.uk

Contents Page

Section	Page
Product Description	
General	3
Motor Protection	3
Operation	
General	4
Initial Powering up	4
Dryer Operation	4
Duty Compressor Selection	4
Duty Filter/Dryer Selection	4
Safety	
General	5
Installation	
Mechanical	5
Siting	5
Pipe work Connections	5
Electrical	5
Electrical Schematics	
Medical Air Plant Connection Diagram	6
Kaeser Compressor Starter Unit	7
Medical Air 2 Pump control Unit	8
Duplex Dryer Control Unit	9
Maintenance	
General	10
Routine Maintenance	10
Vessel Maintenance	10
Fault Diagnosis	11
Spare Parts	
Recommended Spare Parts	12

Product Description

1.1 General

The Plant consists of;

A vertical Air Receiver fitted with an Automatic and Manual Drain Valve, a Pressure Gauge and a Pressure Relief Valve.

Duplex oil flooded Rotary Screw Compressors each fitted with After Coolers, Flexible Hoses and Anti – Vibration Mountings.

Duplex 1 micron oil/water Separation Filters each fitted with Differential Pressure Gauge and Automatic Float Type Drain Valve.

Duplex Desiccant Regenerating Dryers with Pressure Gauges fitted to each column.

Duplex activated Carbon filters for odour and dust removal each fitted with Manual Drain Valve.

Duplex 0.1 micron Medical Sterile filters each fitted with Differential Pressure Gauge and Manual Drain Valve.

Duplex Pressure Reducing Regulator set, and Line Pressure Relief Valve Assemblies..

Duplex Compressor Starter Panels incorporating Isolators, Motor Breakers, Contactors, Hand/Auto Switches, Indicators for; Mains On, Compressor Running, Control Circuit Failed, Motor Tripped, Over Temperature and Compressor Failed. Each Compressor has a Reset Button.

A Plant Control Unit incorporating a Pressure Gauge, a Duty Selector Switch with auto selection, and a Plant Emergency Run Pressure Switch. Status Indicators for Normal, Plant Fault, Plant Emergency, Reserve Low system fault, Pipeline Pressure Fault 4 bar, and Pipeline Pressure Fault 7 bar.

All Alarm Contacts are duplicate allowing complete dual Alarm System or BMS/Alarm Connection.

A Dryer Control Unit incorporating Duplex PLC's for Cycle Timing, Hand/Auto Switches, a Dew Point Sensing Circuit to detect moisture after the Dryers and Line Pressure Sensors for high and low Pressure in the Line.

1.2 Motor Protection

Each Compressor Motor has a Manual Motor Breaker and Contactor. They operate when the motor connected draws excessive current or if a phase is lost.

The trip current is set on the disc on the front of the breaker at the factory and should not need adjustment. There is a Manual Switch that allows testing of the unit.

GENERAL NOTE; it is recommended that all electrical work be carried out by a qualified electrician.

Operation

2.1 General

Once powered up, the Duty Compressor starts immediately followed by the Standby Compressor, the Compressor Failed Lamps and the Dryer Pressure Fault Lamps may be on.

Once the Duty and Standby Compressors have stopped then press both Compressor and the Dryer Reset Switches and, if the dryer will not reset to normal the dryers may be wet. Try running both dryers on "Continuous" for 30 minutes while also leaking a little air from the test point to allow a flow of dry air over the dew-point transmitter. The dryer should now reset to normal.

At 10 bar the Duty and the Standby Compressor will Stop. The Duty Compressor Maintains pressure in the receiver between 9 and 10 bar, if the Duty Compressor fails or cannot cope with the System demand, the Standby Compressor is activated at 8.5 bar.

In the event of both Compressors failing the Plant Emergency Switch will Activate at 8 bar, the Dryer Fail Pressure Switch will operate at 6.5 bar followed by the Line Pressure transducer.

2.2 Initial Powering up

Check direction of rotation of Compressors, if incorrect reverse polarity by changing two phases around.

Check oil levels are O.K.

2.3 Dryer Operation

The Dryer operates automatically in synchronization with the Compressors. Both Dryers are fitted with Economy/Continuous Switches, which allow manual operation for maintenance purposes.

In Auto Mode the Dryer can be seen to operate only when the Compressors run. This uses air to regenerate only when a demand exists (Economy Mode).

The operation time is a 12-minute cycle, each tower being on stream for 6 minutes. During the last minute of each towers cycle, the Dump Solenoid Valves close to allow pressure to equalise in both columns ready for changeover. This time stops and starts with the Compressors in Auto Mode but can best be time checked in hand.

2.4 Duty Compressor Selection

The duty Selector Switch on the Control Panel indicates the Duty Compressor.

2.5 Duty Filter/Dryer Selection

The Dryer Control Panel has a Duty Selector Switch for Manual Selection of the Dryer/ Filter Set, however, in the event of a Dryer fault the selected (failed) Dryer is isolated and the Standby Dryer automatically put on stream.

Both Dryers have Manual Isolation Ball Valves on Inlet and Outlet sides all should be left open to allow auto changeover. These Valves are only for servicing and maintenance use.

Safety

3.1 General

This equipment should be installed, operated and maintained by personnel who are suitably trained, are fully conversant with HTM 2022 and are familiar with this product.



This equipment should be kept clean and be free from oil and grease at all times. Oxygen will ignite spontaneously in the presence of oil and grease. If you suspect that any equipment is contaminated, do not use it.

No attempt should be made to use or modify this equipment for use with a gas other than as identified.

This equipment should not be operated at pressures exceeding those stated in HTM 2022 and this manual.

Installation

4.1 Mechanical

The Plant is designed to be floor mounted. The Compressor Unit should be mounted on the pads provided, the legs of the receiver and the Dryer Frame should be fastened direct to the floor through the frame Mounting Brackets. The mounting holes in the Receiver and Dryer are 10 mm diameter.

4.2 Siting

Plant room ambient temperature should be between 10°C and 40°C. Oil flooded machines suffer from oil emulsification at low temperatures due to heated gases being drawn into the pumps via the intake, which condense and mix with the oil. Therefore the plant room may need to be heated.

4.3 Pipe work Connections

Once sited connect the flexible pipe from the Compressors to the Vessel Pipe work and the Vessel to the Dryer Pipe work at the rear 15mm dryer Inlet Port.

The pipeline connection to the Plant is provided by a Union Stub on the right hand side of the Control Panels connections are 22mm copper.

All connections should be made in accordance with the connection diagram overleaf.

4.4 Electrical

Electrical power supply should be provided via two, three phase + neutral + earth supplies and fused to the compressor starter panels. Plus a single phase+ neutral + earth supply fused at 5 amps to the dryer panel.

4.5 Piping / Connection diagram

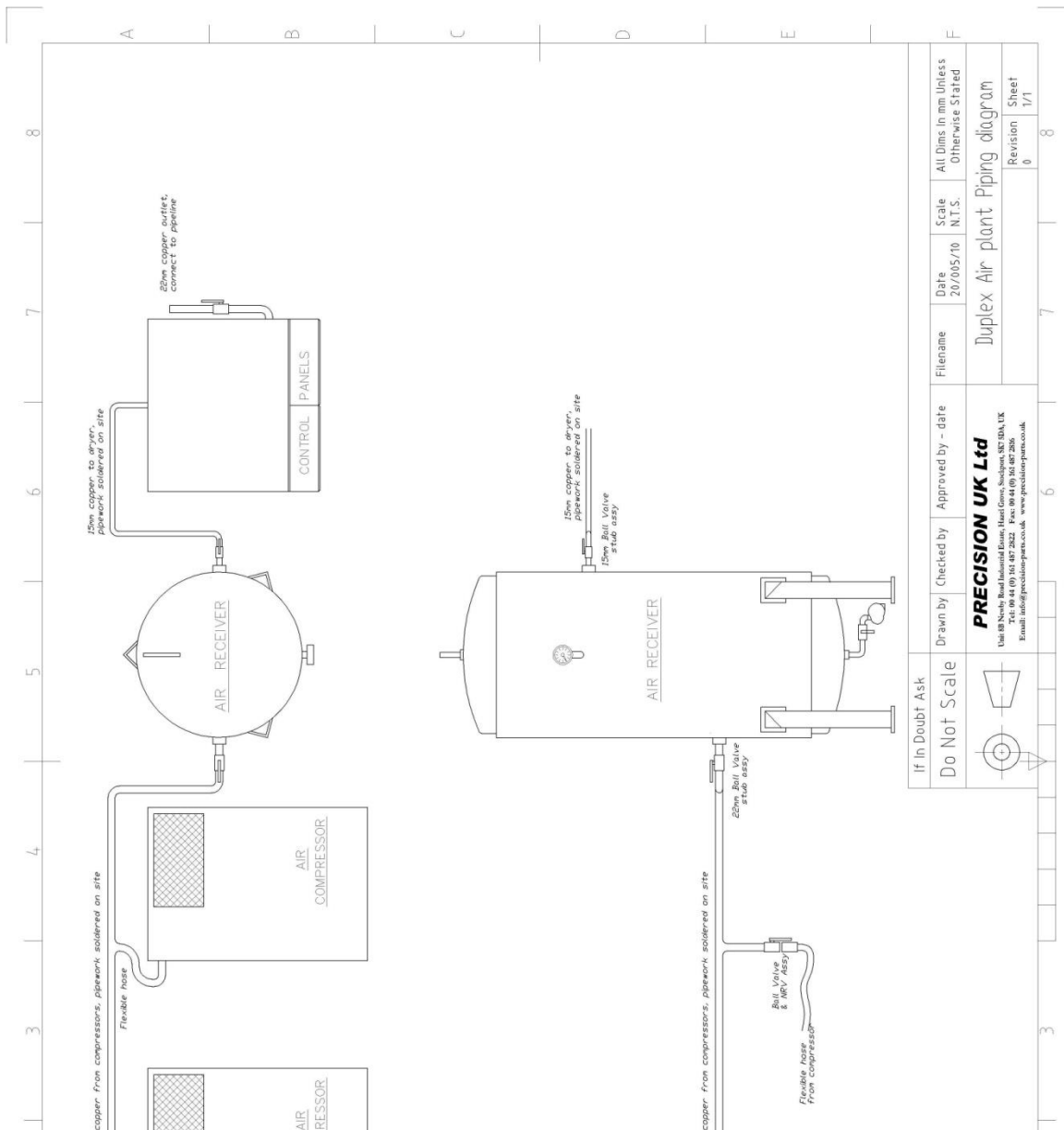



CPX Technology Building, Hazel Grove,
 Stockport, Cheshire, SK7 5BW
 Tel: +44 (0) 161 487 2822
 Fax: +44 (0) 161 487 2816
 Email: info@precisionuk.co.uk

Electrical Schematics

5.1 Kaeser compressor Starter Unit

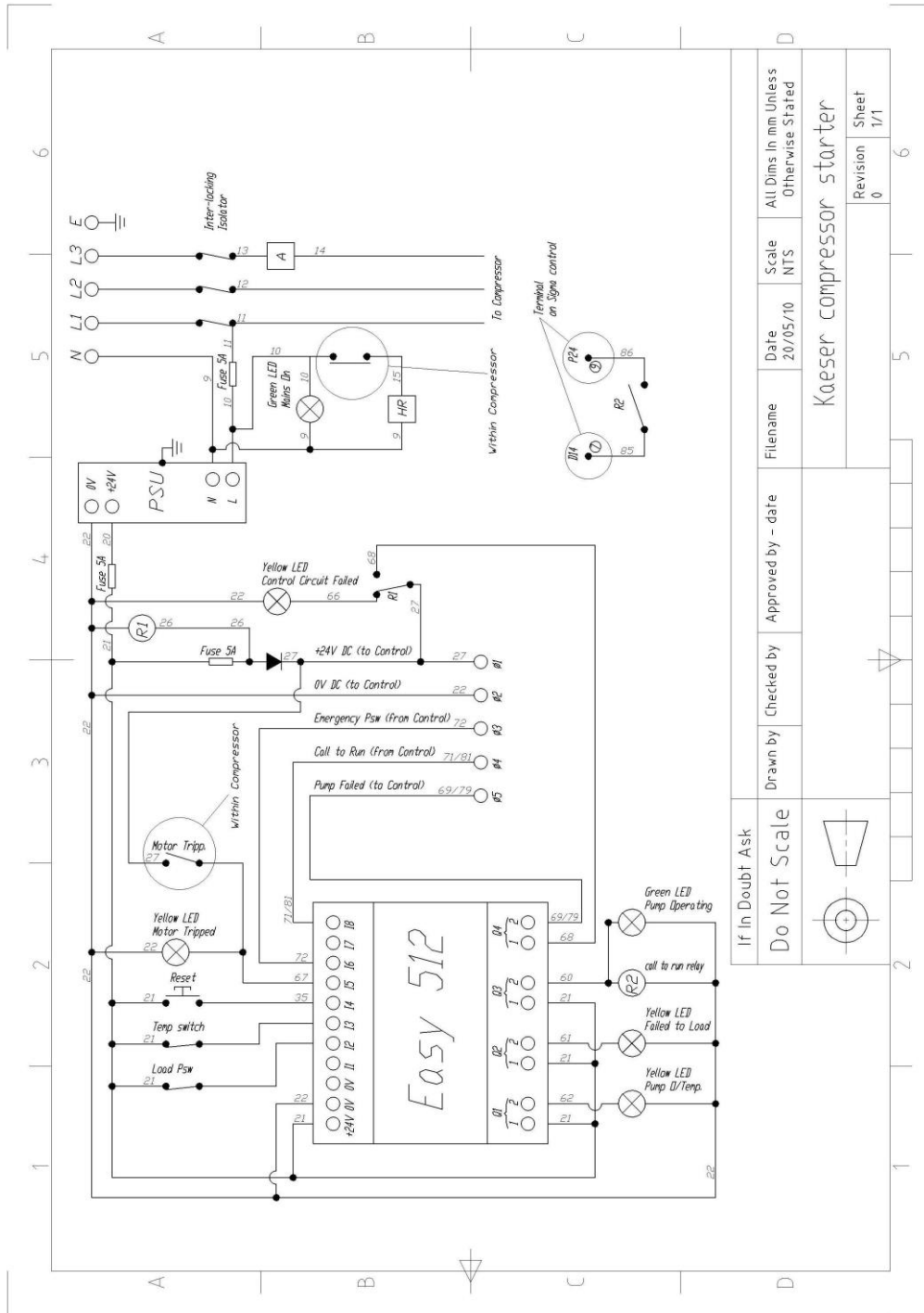



If In Doubt Ask		Approved by - date		Filename		Date		Scale		All Dims in mm Unless Otherwise Stated	
Do Not Scale				Kaeser compressor starter		20/05/10		NTS			
										Revision Sheet 0 1/1	

5.2 Medical Air 2 Pump Control Unit

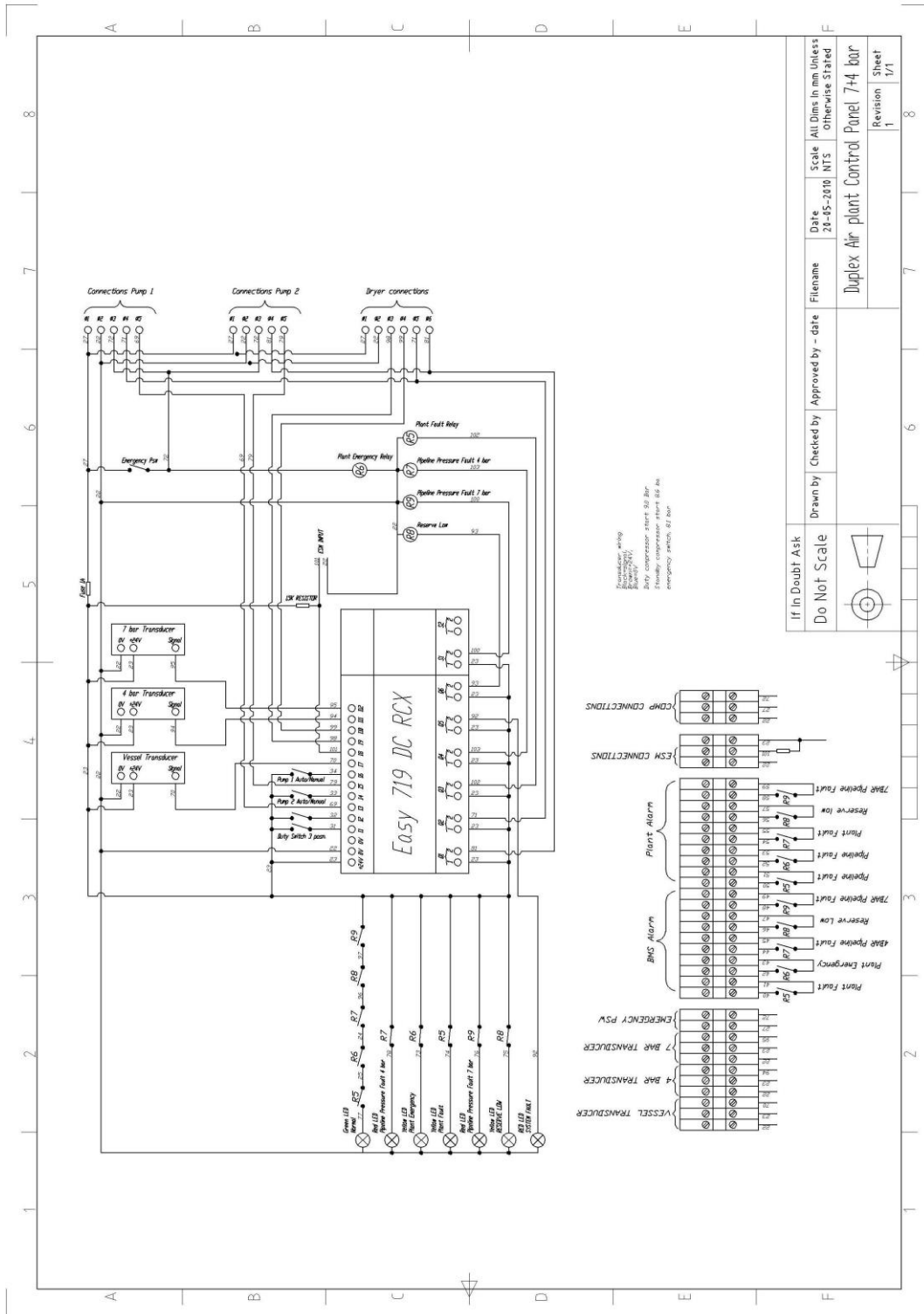

www.precisionuk.co.uk



Company Registered Office: Crown House, Stockport, Cheshire, SK1 3RB
 Registered in England and Wales No. 05058855
 VAT No. 850 0700 67

CPX Technology Building, Hazel Grove,
 Stockport, Cheshire, SK7 5BW

Tel: +44 (0) 161 487 2822

Fax: +44 (0) 161 487 2816

Email: info@precisionuk.co.uk

5.3 Duplex Dryer Control Panel

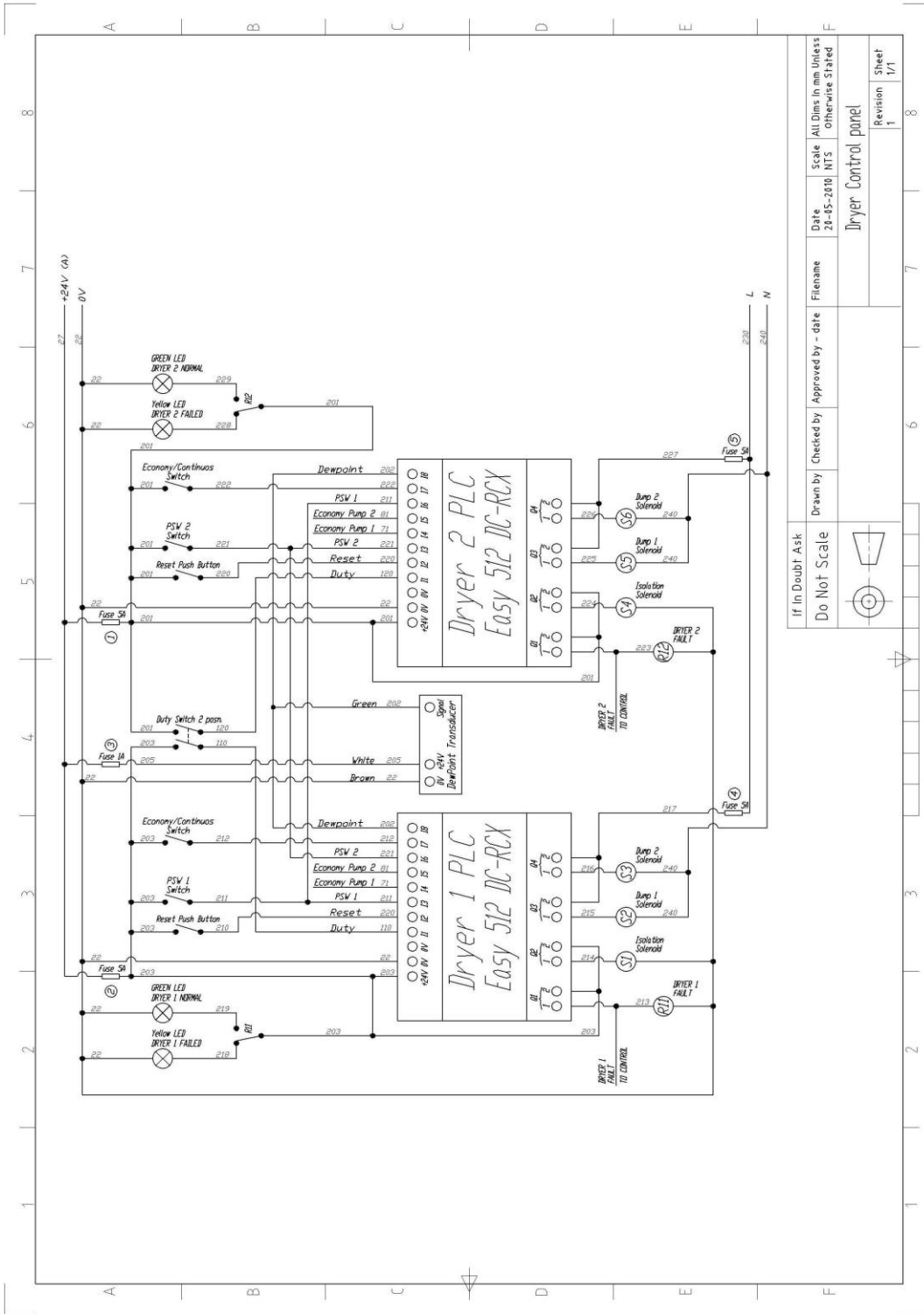

If In Doubt Ask	Drawn by	Checked by	Approved by - date	Filename	Date	Scale	All Dims in mm Unless otherwise Stated
Do Not Scale					20-05-2010	NTS	
				Dryer Control panel			
							Revision Sheet 1/1

www.precisionuk.co.uk



Company Registered Office: Crown House, Stockport, Cheshire, SK1 3RB
 Registered in England and Wales No. 05058855
 VAT No. 850 0700 67

CPX Technology Building, Hazel Grove,
 Stockport, Cheshire, SK7 5BW
 Tel: +44 (0) 161 487 2822
 Fax: +44 (0) 161 487 2816
 Email: info@precisionuk.co.uk

Maintenance

6.1 General

The two most important items to consider are oil and filters.

Oil should be changed every 6 months or 1000 hours whichever comes first.

Pre and activated Carbon Filters should be replaced at 12-month intervals but Sterile filters every 6 months.

6.2 Routine Maintenance

WEEKLY;

**Check Vessel Drain operation.
Check oil levels, top up if necessary.
Check Compressor hours
Select Duty Compressors based on hours run. If even set to auto.
Change Duty Dryer.**

MONTHLY;

**Check Drain on Receiver using Manual Valve.
Check each Compressor runs O.K. using Manual/Auto Switches (run for no less than 10 minutes each Compressor).**

EVERY 6 MONTHS;

Change Sterile Filter Elements.

EVERY 12 MONTHS;

**Check all Pressure relief valves
Send Pressure transducers for calibration.
Send dew-point transducer for calibration.
Change oil in Compressors.
Any other maintenance to the compressors as recommended by the manufacturer
Tighten Electrical Connections.
Check all Switch settings.
Change Pre and Active Carbon Filter Elements.**

6.3 Vessel Maintenance

Periodic insurance inspection will be required on the Pressure Vessel. The Vessel is provided with two inspection ports, one on each end.

6.4 Fault Diagnosis

SYMPTOM.	FAULT.	ACTION
Motor will not start.	Circuit breaker tripped/blown.	Check all Electrical Switchgear, Cables and Motor.
	Motor burnt out.	Return Compressor for repair.
	Overload tripped	Isolate Supply Power, reset Overload Trip.
Standby Compressor Running.	Motor or Air temp is high	Ensure Inlet to Motor Fan or After Cooler is not obstructed.
	Duty Compressor failed.	Check Motor is running.
	Plant overuse.	Check sizing.
Dryer Pressure fault.	Filter element blocked.	Replace filter.
	Pressure Switch faulty.	Reset set Point.
Dryer Dew point fault.	Dryer hang up.	Check solenoids.
	Desiccant Saturated	Change Desiccant, dry for 30mins by running on manual Then Reset.
	Dew-point Sensor needs calibrating	Calibrate Dew-point sensor
Reserve Lamp on.	E.S.M. empty.	Check ESM.
System Fault.	Fault in ESM Wiring.	Check ESM Wiring
Line Pressure fault.	Regulator set point low or high.	Check setting.
	Line Pressure Transducers Need Calibrating.	Calibrate Transducers.

Spare Parts

2 x Compressor Air Intake Filter Elements.

15L Compressor Oil

2 x n/o Pressure Switch.

1 x 0-10bar, 0-10V Pressure transducer.

2 x Pre – Filter Elements.

2 x Activated Carbon Filter Elements.

2 x Sterile Filter Elements.

1 x Filter Auto Drain Unit (float type).

1 x Regulator Repair Kit.